

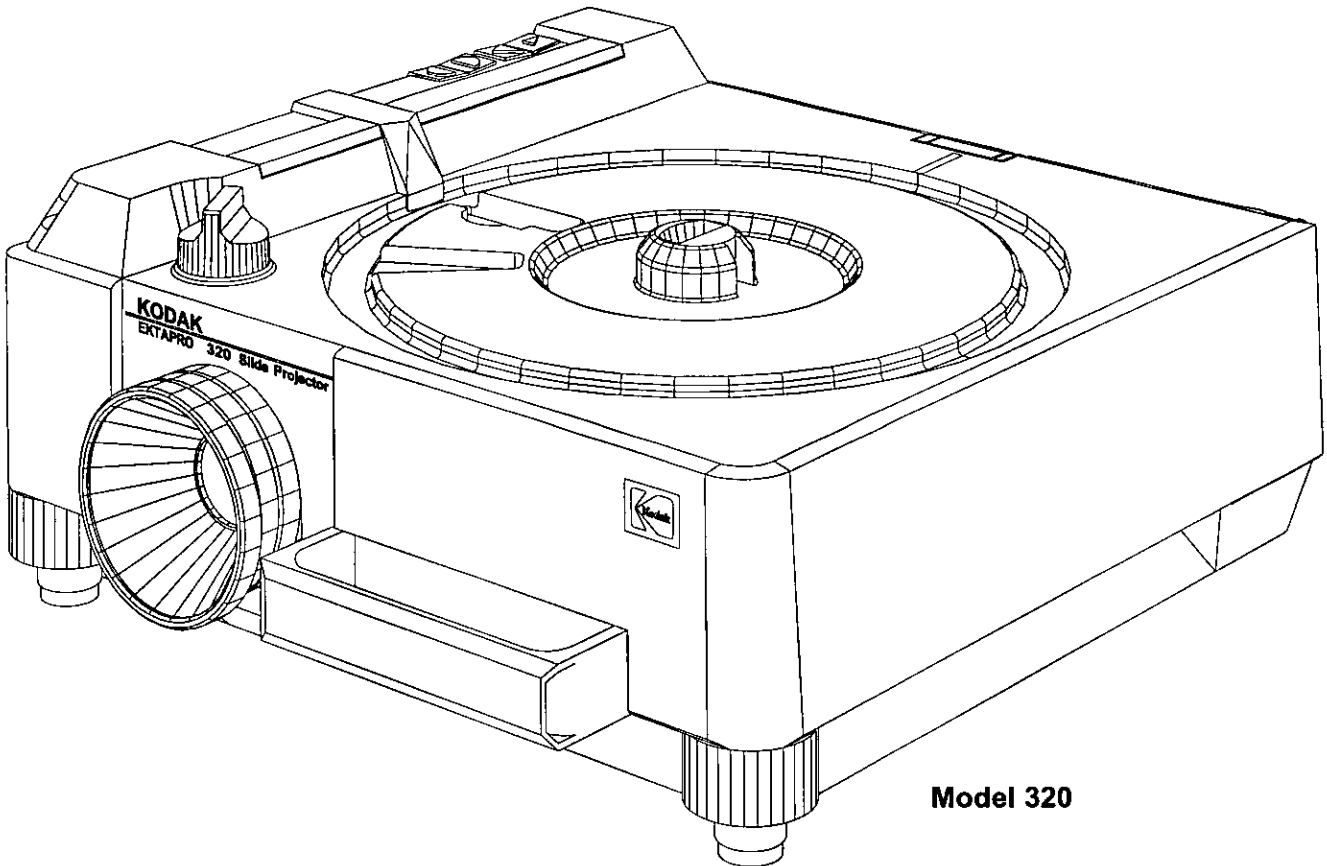

WIRING DIAGRAMS

for the KODAK EKTAPRO Slide Projector Model 320



Model 320

PLEASE NOTE

The information contained herein is based on the experience and knowledge relating to the subject matter gained by Kodak prior to publication. No patent license is granted by this information. Kodak reserves the right to change this information without notice, and makes no warranty, express or implied, with respect to this information. Kodak shall not be liable for any loss or damage, including consequential or special damages, resulting from the use of this information, even if loss or damage is caused by Kodaks negligence or other fault.

TABLE OF CONTENTS EKTAPRO 320 WIRING DIAGRAMS

Section	Page
Block Diagram	1
Power Supply (Masterboard Sheet 1 of 4)	2
Microcontroller (Masterboard Sheet 2 of 4)	3
Stepper Motor Drivers (Masterboard Sheet 3 of 4)	4
Focus Motor and Shutter Solenoid Driver (Masterboard Sheet 4 of 4)	5
Keyboard PCB.....	6
Tray Motion PCB	6

EKTAPRO 320 BLOCK DIAGRAM

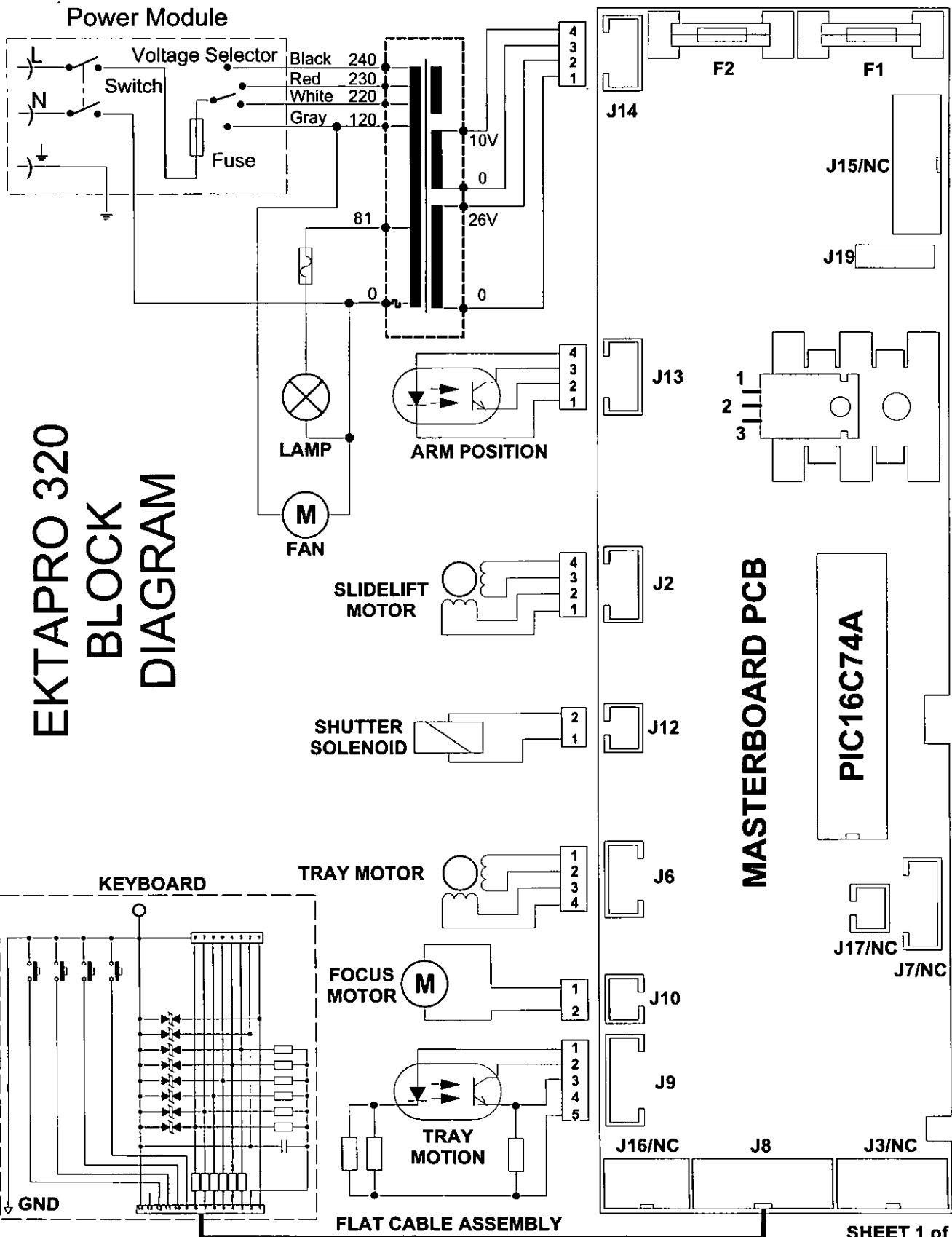

POWER SUPPLY EKTAPRO 320

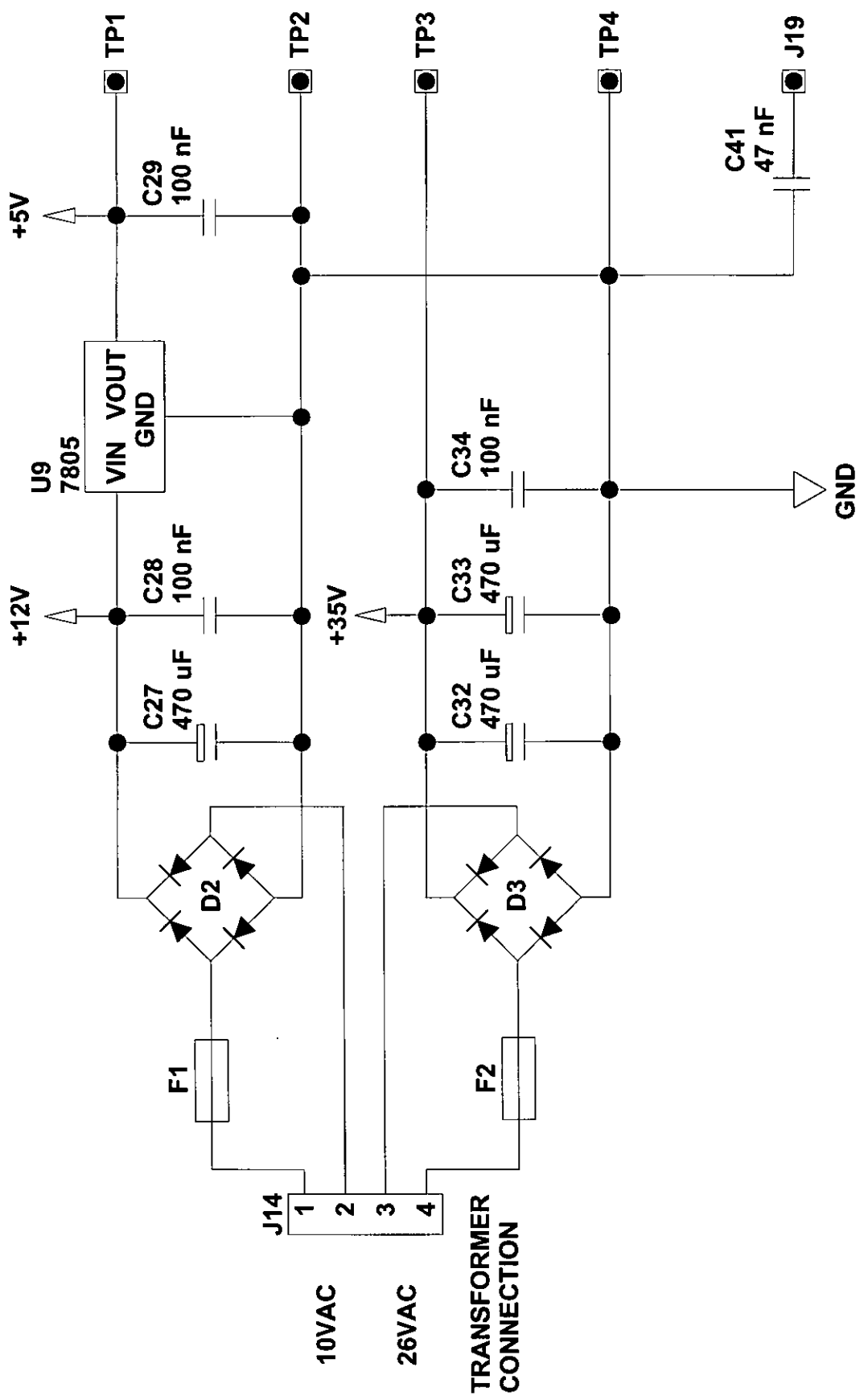

SHEET 1 of 4

EKTAPRO 320 MICROCONTROLLER

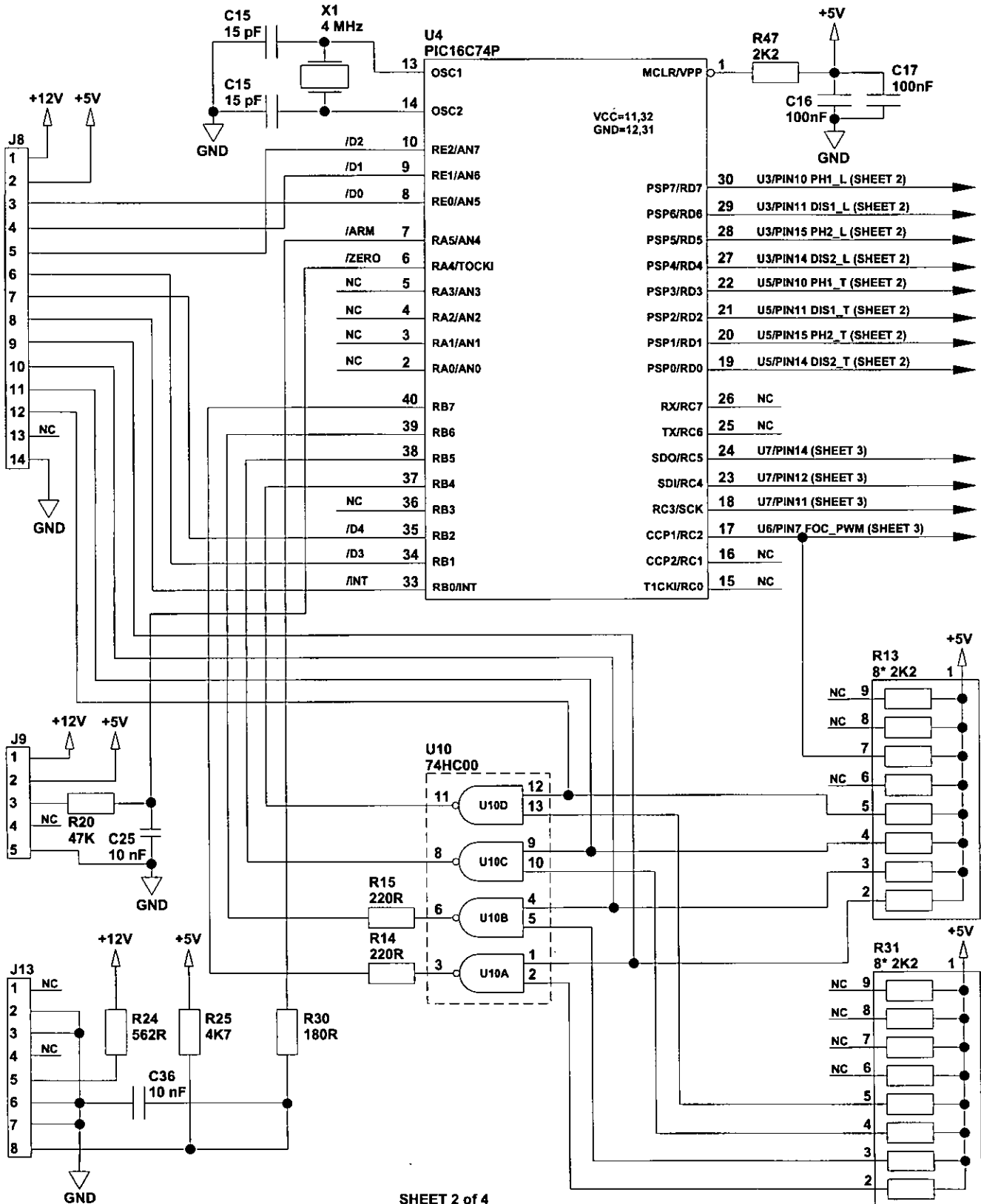

SHEET 2 of 4

EKTAPRO 320 STEPPER MOTOR DRIVER - SLIDLIFT

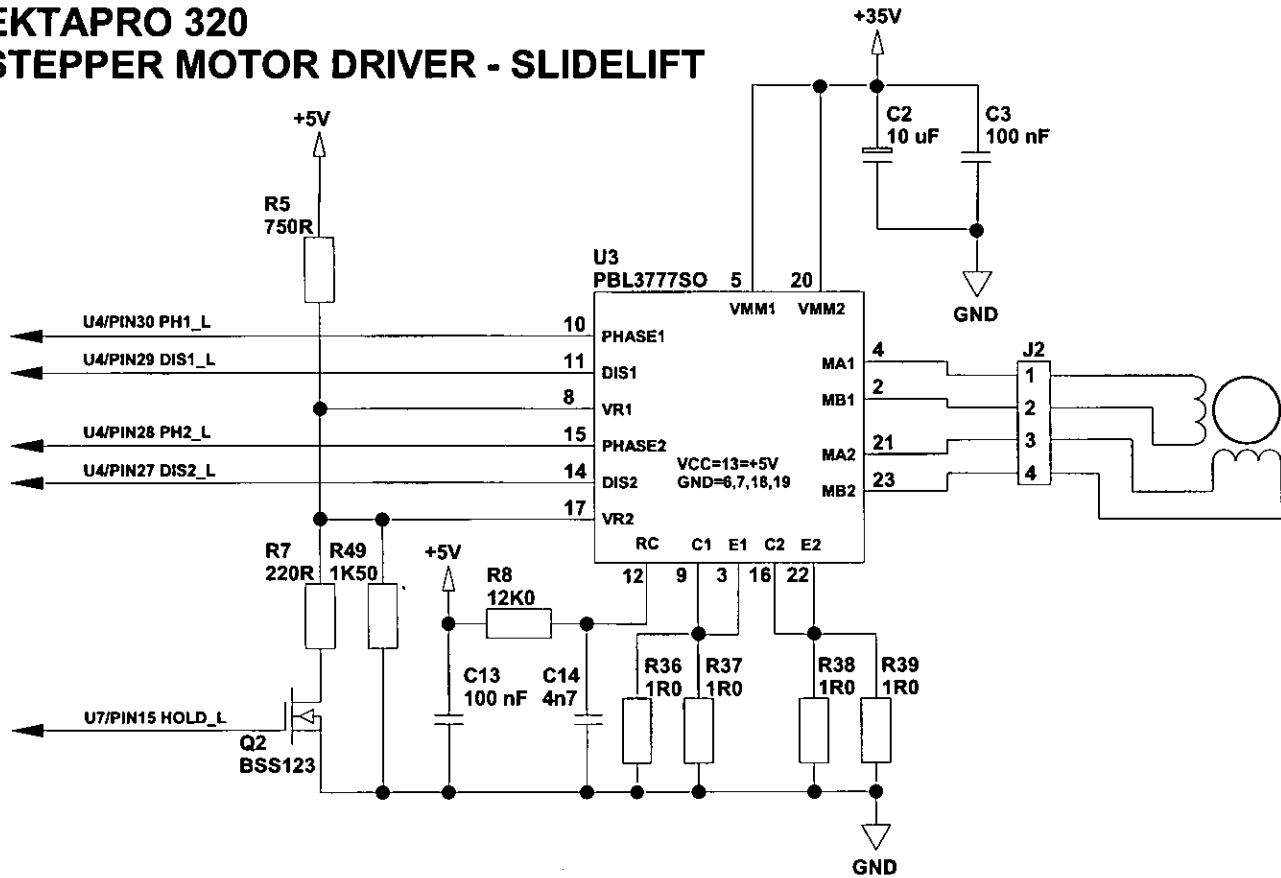

EKTAPRO 320 STEPPER MOTOR DRIVER - TRAY

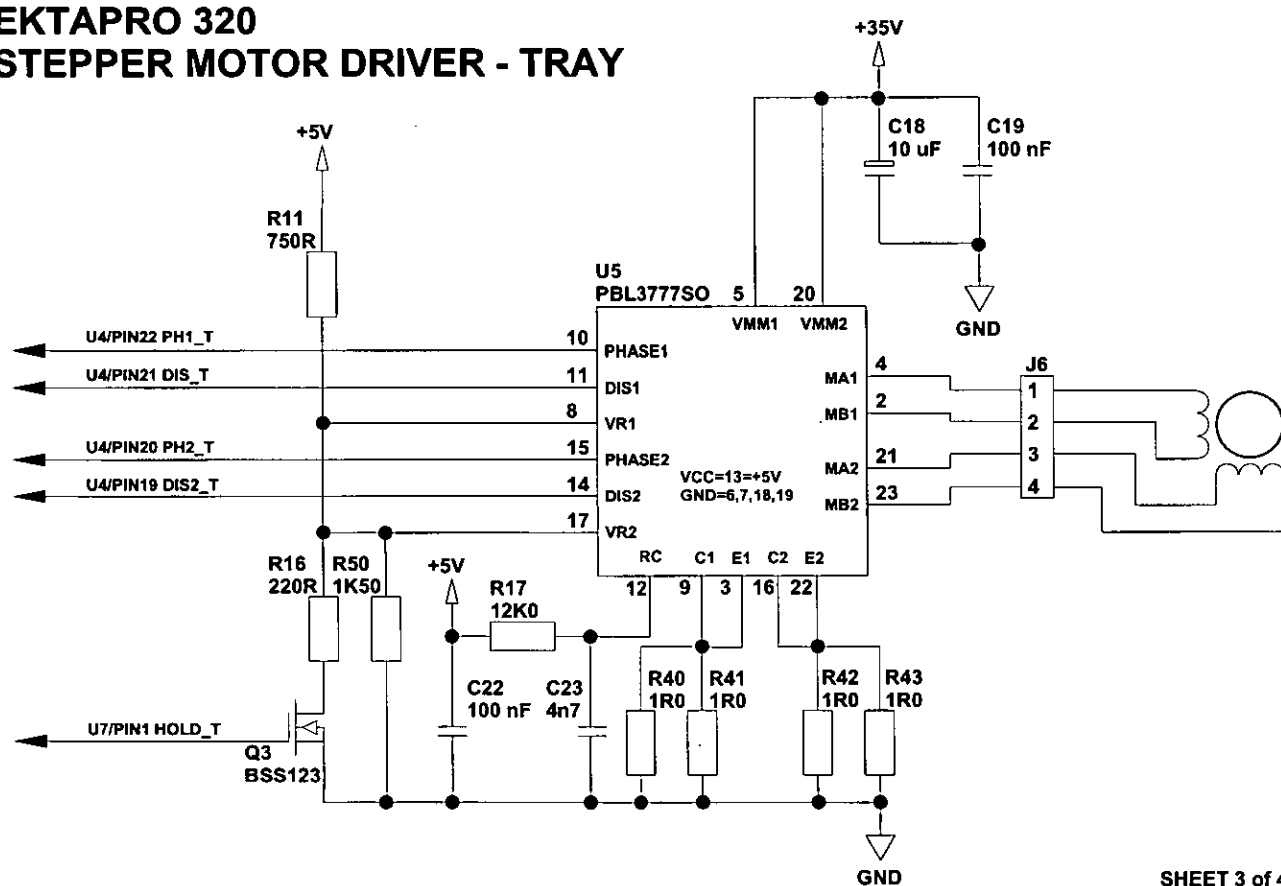

EKTAPRO 320 FOCUS MOTOR DRIVER

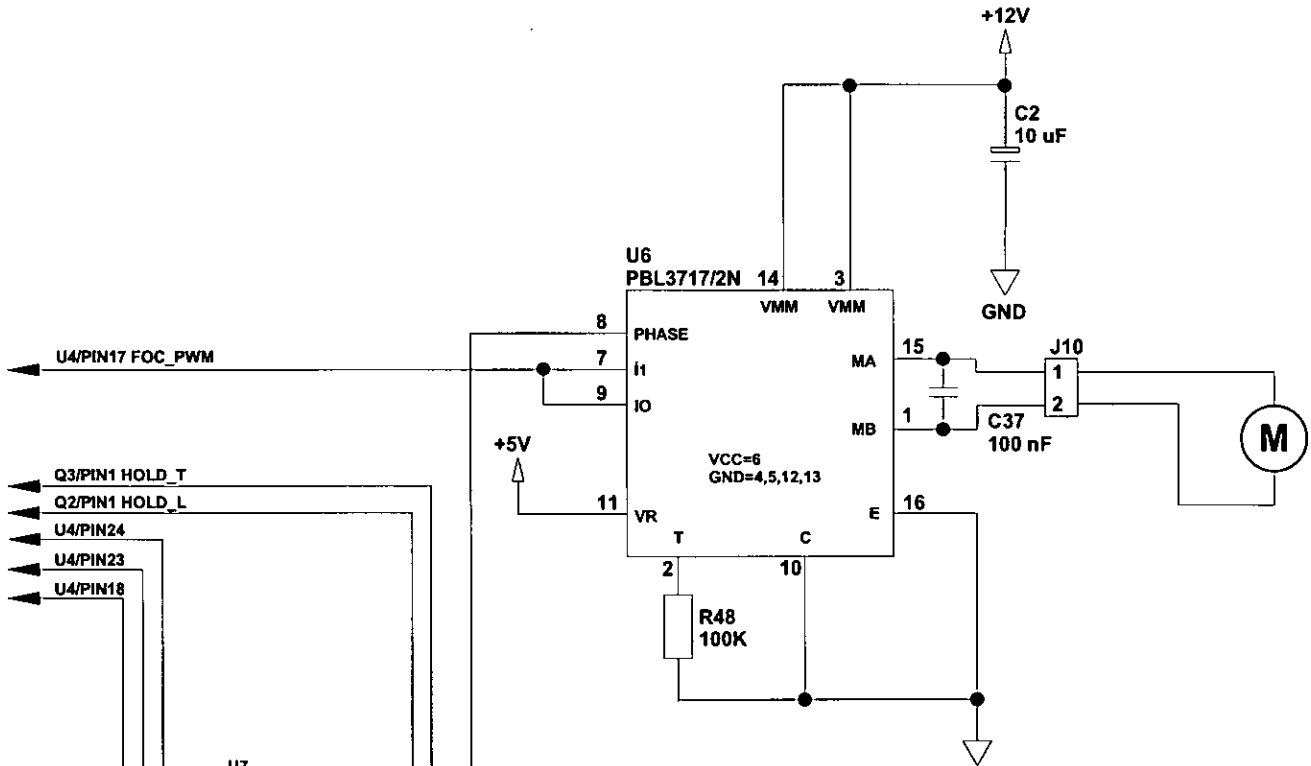

EKTAPRO 320 SHUTTER SOLENOID DRIVER

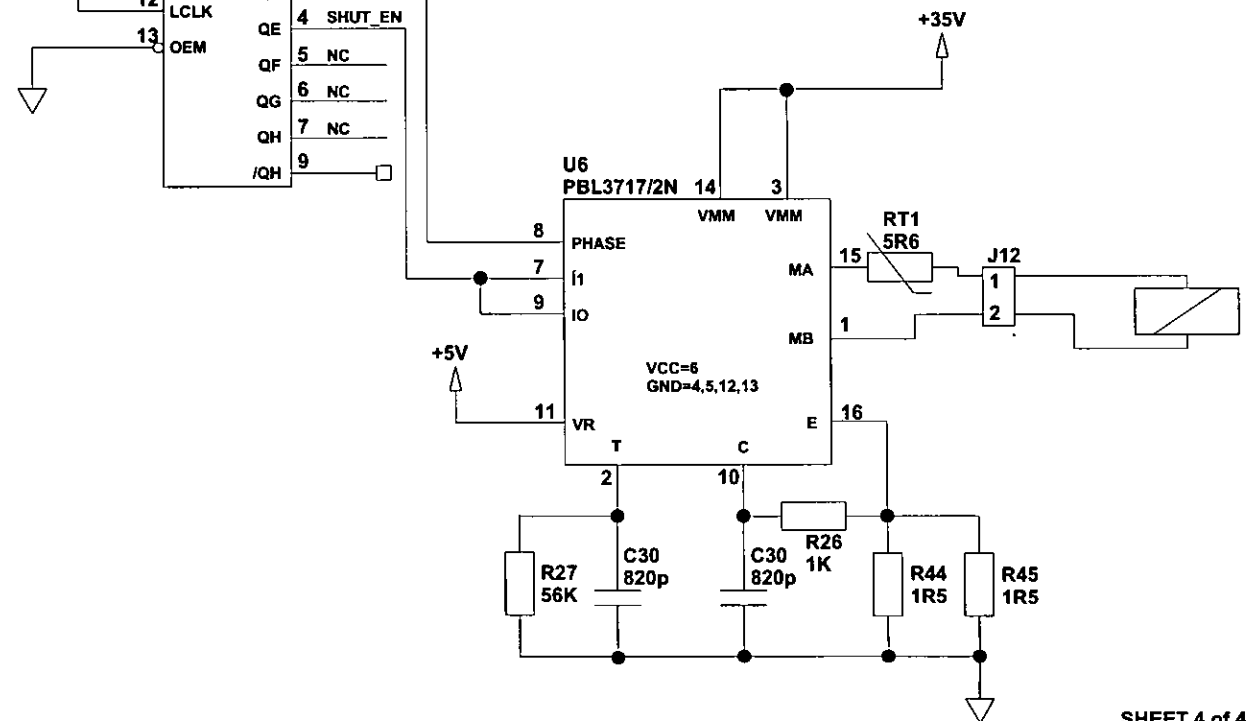

EKTAPRO 320 KEYBOARD

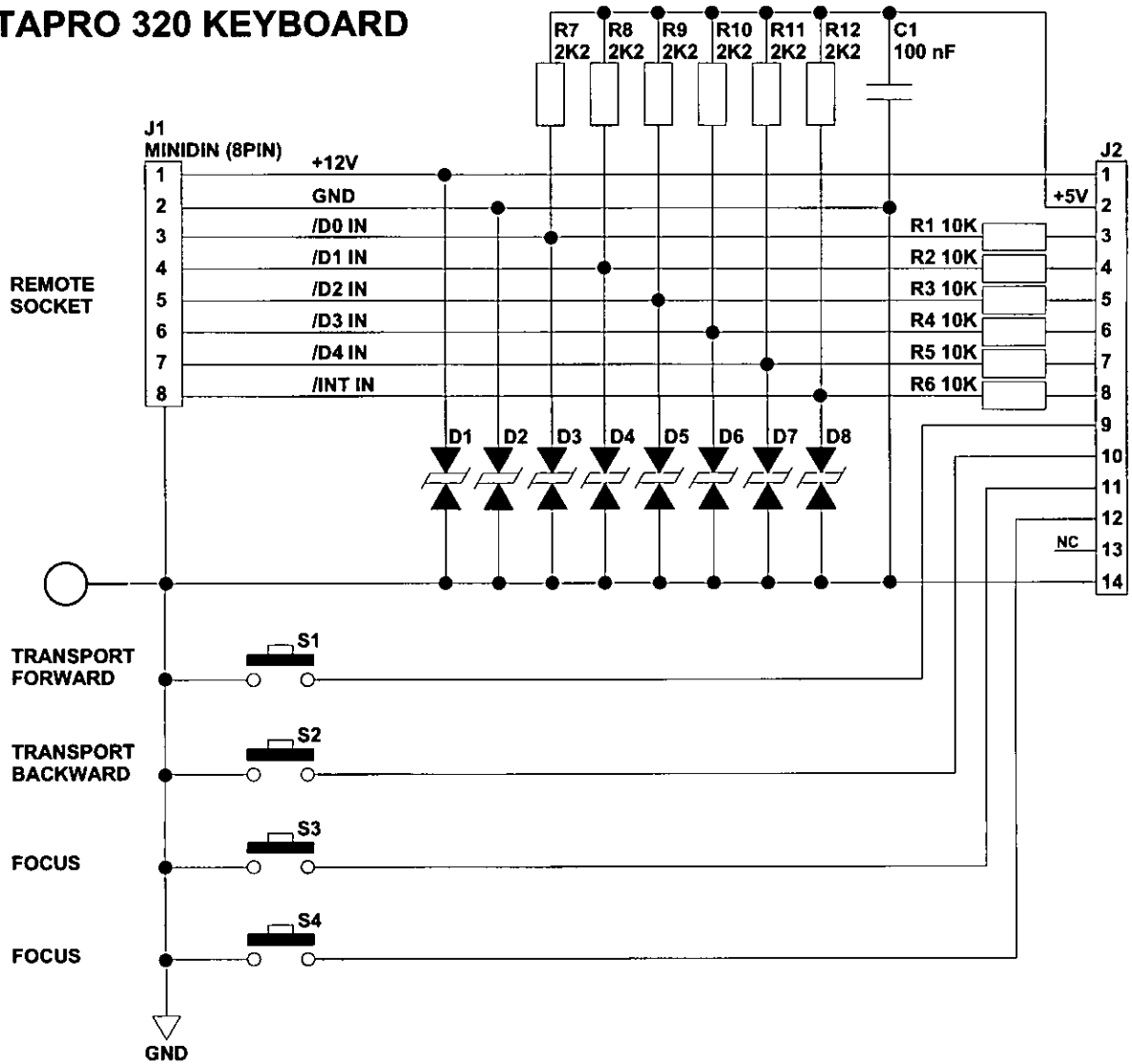

EKTAPRO 320 TRAY MOTION PCB

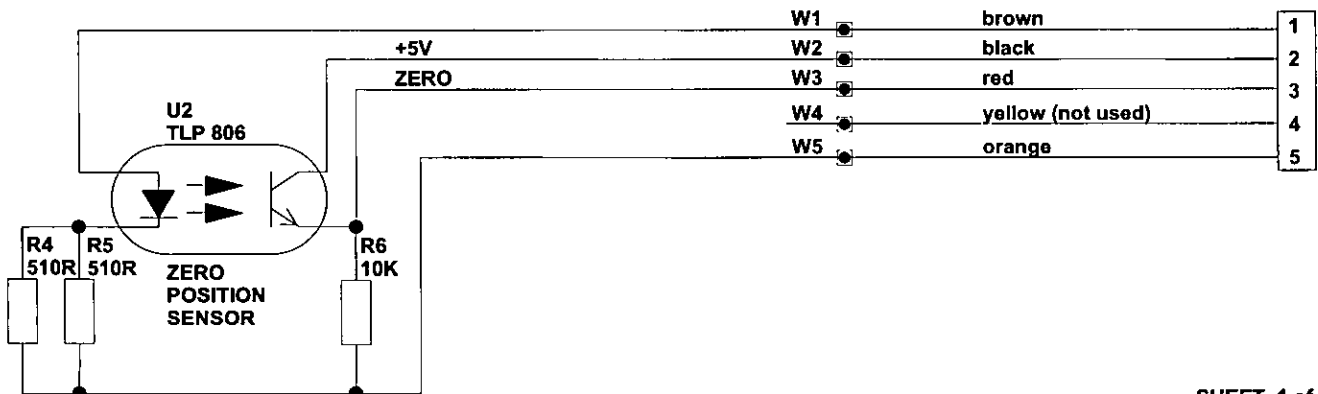

SHEET 1 of 1

Compliments of:
www.KodakParts.com



CUSTOMER EQUIPMENT SERVICES KODAK AG STUTTGART GERMANY